



PRODUCT LINE OVERVIEWS

Multivoltage electronic timers



Voltage
Types
Selection/Pricing Page
Technical Data Page
Functions
Delayed ON
ON delay with auxiliary contact
ON delay + instantaneous contact
OFF delay
OFF delay with auxiliary contact
ON + OFF delay with auxiliary contact
Impulse ON
Impulse ON with auxiliary contact
OFF pulse with auxiliary contact
Symmetric intermittence
Asymmetric intermittence
Star-delta starter
Multifunction
Features
Multirange of time
Time setting range from to
Relay output (Nr. of changeover contacts)

Multivoltage											
MTCV	MTCVL	MTCV	MTCCV	METV	MTDV	MRDV	MICV	MIFV	MIVV	MIVL	MMFV
2	2	2	2	2	3	2	2	3	3	3	3
12	12	13	14	15	16	15	13	17	18	19	20
•	•										•
			•								•
		•									
				•	•						
				•							•
											•
							•				•
								•			•
				•							•
											•
•	•	•	•		•		•	•	•	•	•
0.6s 60 min.	0.06s 60 h	0.6s 60 min.	0.6s 60 min.	1 60 s	0.6s 60 min.	0.5 500 s	0.6s 60 min.	0.6s 60 min.	0.6s 60 min.	0.6 60h	0.6s 50 min.
1 2	1 2	1del+ 1 inst	1	1	1	1 2	1 2	1 2	1 2	1 2	1 2

Protective relays



Voltage
Types
Selection/Pricing Page
Technical Data Page
Functions
Liquid level detection
Differential ground fault
Integral protection for three-phase lines
Unbalance and phase failure protection
Unbalance, phase failure and min. voltage protection
Phase sequence and phase failure protection
Max. and min. voltage protection (three-phase)
Max. and min. voltage protection (single phase)
Voltage detection
Current detection
Current detection with delay (0.5-15s)
Thermistor
Thermistor (adjustable)
Frequency control

Single voltage													
DINIL	RDH/T/A	RDF1	RPDF	RDMT1	RSFF	RTMM	RMM	RDT	RDI	RDIT	RS01N	RSR	RCF
4	5	6	6	6	6	6	6	7	7	8	9	9	9
21	25	26	27	28	29	30	30	31	32	33	34	35	35
•													
	•												
		•											
			•										
				•									
					•								
						•							
							•						
								•					
									•				
										•			
											•		
												•	
													•

Ordering data, see p.2-9
 Technical data, see p.10-36
 Dimensional drawings, see p.37-38



Multivoltage electronic timers



MTCV



MTCIV



MRDV

Supply voltage	Time range	Available contacts	Cat. no. ⁽¹⁾	List Price, GO-10RT
Delayed ON timers				
Direct	0.6 - 6 sec.	1 selectable NO-NC	MTCV	\$61.00
24-240V AC/DC	6 - 60 sec.	2 selectable NO-NC	MTCV2	75.00
With transformer	0.6 - 6 min. 6 - 60 min.	1 selectable NO-NC	MTCVT●	79.00
Long time delayed ON timers				
Direct	0.06 - 0.6 sec.	1 selectable NO-NC	MTCVL	64.00
24-240V AC/DC	0.6 - 6 sec.	2 selectable NO-NC	MTCVL2	78.00
With transformer	0.6 - 6 h. 6 - 60 h.	1 selectable NO-NC	MTCVLT●	82.00
Delayed ON timer with instantaneous contact				
Direct	0.6 - 6 sec.	1 timed contact	MTCIV	64.00
24-240V AC/DC	6 - 60 sec.	+ 1 instant contact		
	0.6 - 6 min.			
	6 - 60 min.			
Delayed ON through contact				
Direct	0.6 - 6 sec.	1 selectable NO-NC	MTCCV	65.00
24-240V AC/DC	6 - 60 sec.			
With transformer	0.6 - 6 min. 6 - 60 min.	1 selectable NO-NC	MTCCVT●	83.00
Impulse ON timer				
Direct	0.6 - 6 sec.	1 selectable NO-NC	MICV	65.00
24-240V AC/DC	6 - 60 sec.	2 selectable NO-NC	MICV2	78.00
With transformer	0.6 - 6 min. 6 - 60 min.	1 selectable NO-NC	MICVT●	83.00
Star-delta starter timers				
Direct 24-240V AC/DC	1 - 10 sec.	2 timed	METV	89.00
With transformer	1 - 60 sec.	2 timed	METVT●	107.00
Delayed OFF timers				
Direct	0.5 - 6 sec.	1 selectable NO-NC	MRDV-6	81.00
24-240V AC/DC	5 - 60 sec.	1 selectable NO-NC	MRDV-60	81.00
	50 - 600 sec.	1 selectable NO-NC	MRDV-600	81.00
	0.5 - 6 sec.	2 selectable NO-NC	MRDV2-6	89.00
	5 - 60 sec.	2 selectable NO-NC	MRDV2-60	89.00
	50 - 600 sec.	2 selectable NO-NC	MRDV2-600	89.00
	With transformer	0.5 - 6 sec.	1 selectable NO-NC	MRDVT-6●
(up to 440V)	5 - 60 sec.	1 selectable NO-NC	MRDVT-60●	93.00
	50 - 600 sec.	1 selectable NO-NC	MRDVT-600●	93.00

Technical data.

Type	see page
MTCV	12
MTCVL	12
MTCIV	13
MTCCV	14
MICV	13
METV	15
MRDV	15

Dimensions, see p.37

Contact diagrams.

1 selectable NO-NC 2 selectable NO-NC 2 timed

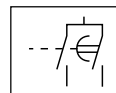
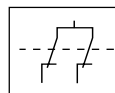
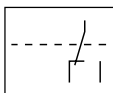

(1) To complete the catalog number, replace the symbol ● with the code corresponding to the voltage. See p.10-11



IEC Electronic Timers & Protective Relays

Available supply voltages

Legend:

●=Available

▲=Recommended stock

Shaded columns indicate UL approved devices, except where marked with *

Current	Direct supply	Supplied with internal transformer									
	AC (50/60 Hz) /DC	AC (50/60Hz)									
	Voltage	24-240	24	48	110 125	110	125	200 240	220 230	240	380 400
Cat No. Code	None	AD	AG	AJ	AJ	AK	AM	EN	AR	AU	
DINIL02		●	●		▲	●		●	●	●	
DINIL02E		●	●		▲	●			●		
DINIL03		●	●		▲	●		●	●	●	
DINIL03E		●	●		▲	●			●		
METV	▲										
METVT				▲			●			●	
MICV	▲										
MICV2	▲										
MICVT				▲			●			●	
MIFV	▲										
MIFV2	●										
MIFVT				▲			●			●	
MIVV	▲										
MIVV2	●										
MIVVL	▲										
MIVVL2	●										
MIVVLT				▲			●			●	
MIVVT				▲			●			●	
MMFV	▲										
MMFV2	▲										
MMFVT2				▲			●			●	
MRDV	▲										
MRDV2	▲										
MRDVT				▲			●			●	
MTCCV	▲										
MTCCVT				▲			●			●	
MTCIV	▲										
MTCV	▲										
MTCV2	▲										
MTCVL	▲										
MTCVL2	▲										
MTCVLT				▲			●			●	
MTCVT				▲			●			●	
MTDV	▲										



MTCV - Delayed ON timer

Function

Electronic relay whose output contact connects with a certain adjustable delay from the moment voltage is applied to supply terminals A1-A2. It has four timing ranges: 0.6-6s, 6-60s, 0.6-6min, 6-60 min. Range selection is made by dipswitches located on the front of the relay. Times are set by front potentiometer controlling an Application Specific Integrated Circuit (ASIC) specially designed for this group of relays. This allows for excellent precision and repeatability features.

Diagram

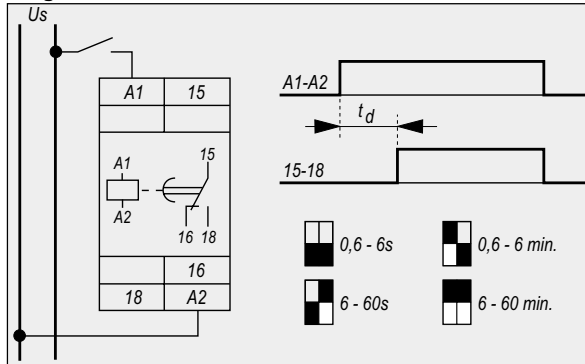

Technical characteristics

Type	MTCV	MTCV2	MTCVT
Number of selectable NO-NC contacts	1	2	1
Output contacts			
Rated insulation voltage U_i	AC	400V	
	DC	250V	
Thermal current I_{th}		6A	
Utilization category AC15			
Rated voltage U_e		120/240V	
Rated current I_e		2.5/1.3A	
Utilization category DC13			
Rated voltage U_e		110/220V	
Rated current I_e		0.2/0.1A	
Supply voltages U_n			
AC (with transformer)	-	-	110-125V
	-	-	200-240V
	-	-	380-440V
DC/AC (direct)	24-240V	24-240V	-
Frequency		50/60 Hz	
Supply voltage tolerance	+10/-20%	+10/-20%	+10/-15%
Consumption	(mA)	50 (24V)	50 (24V)
	(mA)	15 (240V)	15 (240V)
	(VA)	-	3.5
Input circuit test voltage (between input, output and group circuits)		4 kV	
Switch ON response time		0.6s-60 min	
Switch OFF response time		100 ms	
Reset time between 2 cycles		100 ms	
Repeat accuracy with 0.85 - 1.1 U_n		2%	
Weight		0.120, .26 lbs.	
Conformity to standards			
VDE 0106	EN 50002		UL 508
VDE 0110	CSA C 22.2 N° 14		IEC 255.5
EN 50001	UL 94		

MTCVL - Long time delayed ON timer

Function

Electronic relay whose output contact connects with a certain adjustable delay from the moment voltage is applied to supply terminals A1-A2. It has four timing ranges: 0.06-0.6s, 0.6-6s, 0.6-6h, 6-60h. Range selection is made by dip-switches located on the front of the relay. Times are set by front potentiometer controlling an Application Specific Integrated Circuit (ASIC) specially designed for this group of relays. This allows for excellent precision and repeatability features.

Diagram

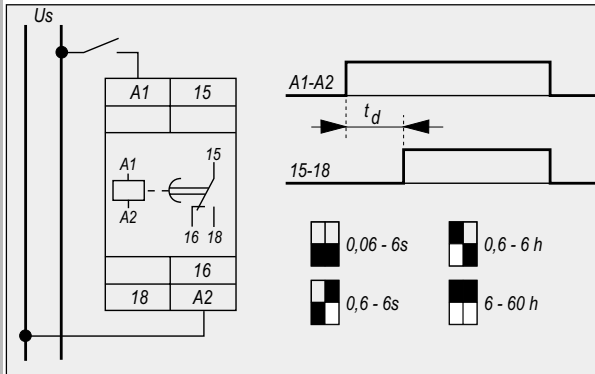

Technical characteristics

Type	MTCV	MTCV2	MTCVT
Number of selectable NO-NC contacts	1	2	1
Output contacts			
Rated insulation voltage U_i	AC	400V	
	DC	250V	
Thermal current I_{th}		6A	
Utilization category AC15			
Rated voltage U_e		120/240V	
Rated current I_e		2.5/1.3A	
Utilization category DC13			
Rated voltage U_e		110/220V	
Rated current I_e		0.2/0.1A	
Supply voltages U_n			
AC (with transformer)	-	-	110-125V
	-	-	200-240V
	-	-	380-440V
DC/AC (direct)	24-240V	24-240V	-
Frequency		50/60 Hz	
Supply voltage tolerance	+10/-20%	+10/-20%	+10/-15%
Consumption	(mA)	50 (24V)	50 (24V)
	(mA)	15 (240V)	15 (240V)
	(VA)	-	3.5
Input circuit test voltage (between input, output and group circuits)		4 kV	
Switch ON response time		0.06s-60 h.	
Switch OFF response time		100 ms	
Reset time between 2 cycles		100 ms	
Repeat accuracy with 0.85 - 1.1 U_n		2%	
Weight		0.115, .25 lbs.	
Conformity to standards			
VDE 0106	EN 50002		UL 508
VDE 0110	CSA C 22.2 N° 14		IEC 255.5
EN 50001			

(1) Reset time: Time that must go by from the relay ends an operation until it is able to initiate the next one without error.

For ambient conditions data, see p.36, Table 2.

Note: The relays have a **green** LED that lights when the relay is energized (flashing during the timing) and a **red** LED that lights when the output contact is made.



MTCIV - Delayed ON timer with instantaneous contact

Function

Electronic relay with two output contacts. One contact connects instantly when voltage is applied to the supply terminals A1-A2 and the other connects with a certain adjustable delay. It has four timing ranges: 0.6-6s, 6-60s, 0-6min, 6-60min. Range selection is made by dip-switches located on the front of the relay. Times are set by front potentiometer controlling an ASIC specially designed for this group of relays. This allows for excellent precision and repeatability features.

Diagram

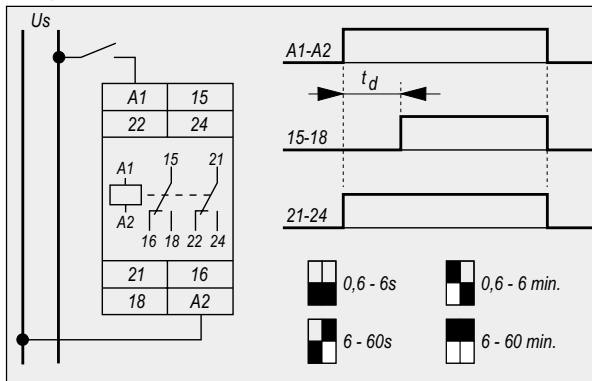

Technical characteristics

Type	MTCIV	
Number of selectable NO-NC contacts	2	
Output contacts		
Rated insulation voltage U_i	AC	400V
	DC	250V
Thermal current I_{th}	6A	
Utilization category AC15		
Rated voltage U_e	120/240V	
Rated current I_e	2.5/1.3A	
Utilization category DC13		
Rated voltage U_e	110/220V	
Rated current I_e	0.2/0.1A	
Supply voltages U_n		
AC/DC (direct)	24-240V	
Frequency	50/60 Hz	
Permissible supply voltage variation	+10% / -20%	
Consumption	50 mA (24V) 15 mA (240)	
Input circuit test voltage (between input, output circuits and earth)	4 kV	
Switch ON response time	0.6s-60 min	
Switch OFF response time	100 ms	
Reset time between 2 cycles	100 ms	
Repeat accuracy with 0.85 - 1.1 U_n	2%	
Weight	0.130, .28 lbs.	

Conformity to standards

VDE 0106	CSA C 22.2 N° 14	IEC 255.5
VDE 0110	UL 94	IEC 947.5.1
EN 50002	UL 508	UNE 20-119
EN 50042		

For ambient conditions data, see p.36, Table 1.

Note: The relays have a **green** LED that lights when the relay is energized (flashing during the timing) and a **red** LED that lights when the output contact is made.

MICV - Impulse ON timer

Function

Electronic relay whose output contact connects when voltage is applied to supply terminals A1-A2. It goes back to stand-by after a preset time. It has four timing ranges: 0.6-6s, 6-60s, 0.6-6min, 6-60min. Range selection is made by dip-switches located on the front of the relay. Times are set by front potentiometer controlling an ASIC specially designed for this group of relays. This allows for excellent precision and repeatability features.

Diagram

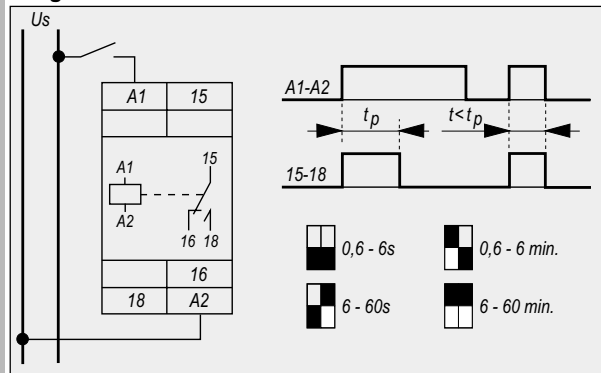

Technical characteristics

Type	MICV	MICV2	MICVT
Number of selectable NO-NC contacts	1	2	1
Output contacts			
Rated insulation voltage	AC	400V	
	DC	250V	
Thermal current I_{th}	6A		
Utilization category AC15			
Rated voltage U_e	120/240V		
Rated current I_e	2.5/1.3A		
Utilization category DC13			
Rated voltage U_e	110/220V		
Rated current I_e	0.2/0.1A		
Supply voltages			
AC/DC (direct)	24-240V	24-240V	-
AC (with transformer)	-	-	110-125V 200-240V 380-440V
Frequency	50/60 Hz		
Supply voltage tolerance	% +10 / -20	+10 / -20	+10 / -15
Consumption	(mA) 50 (at 24V) (mA) 15 (at 240V) (VA) -	50 (at 24V) 15 (at 240V) -	- - 3.5
Input circuit test voltage (between input, output and ground circuits)	4 kV		
Switch ON response time	100 ms		
Switch OFF response time	0,6s - 60 min. (adjustable)		
Reset time between 2 cycles	100 ms		
Repeat accuracy with 0.85 - 1.1 U_n	2 %		
Weight	0.120, .26 lbs.		

Conformity to standards

VDE 0106	CSA C 22.2 N° 14	IEC 255.5
VDE 0110		IEC 947.5.1
EN 50002	UL 508	UNE 20-119
EN 50042		



MTCCV - Delayed ON through contact timer

Function

Electronic relay whose output contact connects with an adjustable delay from the moment voltage is applied to terminals Y1-Y2. This is done by a voltage free control contact and it disconnects the moment the terminals are disconnected. The relay must be supplied with the nominal voltage between A1-A2. Lack of supply voltage will cause immediate disconnection. It has four timing ranges: 0.6-6s, 6-60s, 0.6-6min, 6-60min. Range selection is made by dip-switches located on the front of the relay. Times are set by front potentiometer controlling an ASIC specially designed for this group of relays. This allows for excellent precision and repeatability features.

Diagram

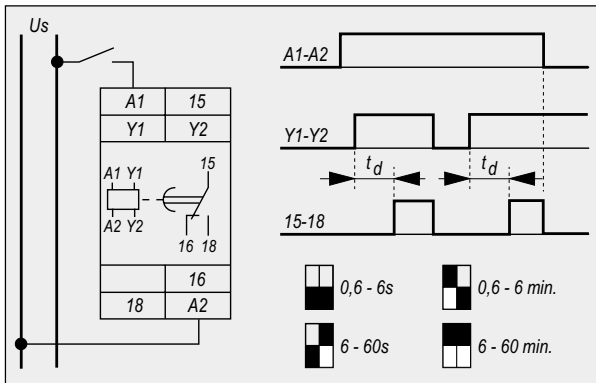

Technical characteristics

Type	MTCCV	MTCCVt
Number of selectable NO-NC contacts	1	
Output contacts		
Rated insulation voltage U_i	AC	400V
	DC	250V
Thermal current I_{th}	6A	
Utilization category AC15		
Rated voltage U_e	120/240V	
Rated current I_e	2.5/1.3A	
Utilization category DC13		
Rated voltage U_e	110/220V	
Rated current I_e	0.2/0.1A	
Supply voltages U_n		
AC (with transformer)	-	110-125V
	-	200-240V
	-	380-440V
DC/AC (direct)	24-240V	-
Frequency	50/60 Hz	
Permissible supply voltage variation	+10% / -20%	+10% / -15%
Consumption	50 mA (24V) 15 mA (240V)	3.5 VA
Input circuit test voltage (between input, output circuit and earth)	4 kV	
Switch ON response time	0.6s-60 min	
Switch OFF response time	100 ms	
Reset time between 2 cycles	100 ms	
Repeat accuracy with 0.85 - 1.1 U_n	2%	
Voltage at open Y1 - Y2 control terminals	15V DC	-
Current through control contact	initial	15 mA
	permanent	1 mA
Weight	0.120, .26 lbs.	
Conformity to standards		
VDE 0106	EN 50002	UL 508
VDE 0110	CSA C 22.2 N° 14	IEC 255.5
EN 50001		